

Mifare® Premium Reader

The Mifare® Premium proximity reader consists of three parts: a potted unit containing the electronics and antenna, a front cover, and an optional spacer plate. A fixed 10 way colour coded cable protrudes from the back of the potted unit.

The reader will read the unique ID from a Mifare® card and output the code in one of many user selectable formats.

The unit also allows the user control of the three LEDs and beeper. A 6 way DIP switch under the front cover is used to select the required output format and LED operational modes.



Specifications

- Power requirements: +5.0 V to +13.6 V DC. Current consumption 100 mA peak, 35 mA average
- Operating Frequency: 13.56 MHz
- Supported cards: MIFARE® Classic, MIFARE® Ultralight, MIFARE® Ultralight C, MIFARE® DESFire, MIFARE® Plus S/X, NFC NTAG
- Contactless interface according to: ISO/IEC 14443 Type A
- Output formats supported: Wiegand (66 bit, 44 bit, 34 bit odd/even parity, 34 bit odd/odd parity, 26 bit), Mag stripe emulation, Clock/Data, RS232 (9600,n,8,1) with both EIA compatible levels and TTL levels
- Continuous output with tag in field or single transmission
- Typical read range: 50 mm for ISO cards, 20 mm for tags
- 3 indicator LEDs (RED, YELLOW, GREEN), controlled by user
- Beeper (4 kHz tone) controlled by user, additionally emits a 50 ms beep when card is read
- Operating temperature range: -20 °C to +60 °C
- 10 way cable: 1m long
- Weight: 95 grams
- Dimensions: Reader 89 x 45 x 17 mm, optional spacer plate 89 x 45 x 7 mm

Physical Dimensions and Mounting Details

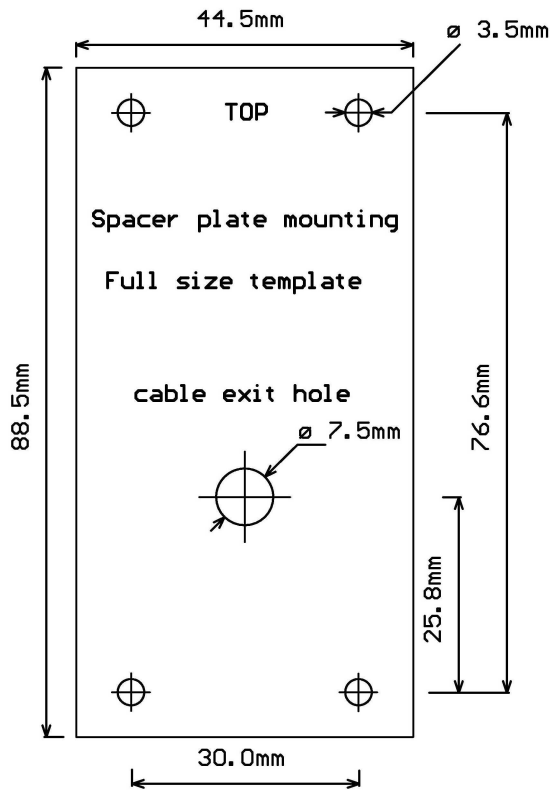

If the spacer plate is used the reader cable may be brought out of one of four exit points on the spacer: top, bottom, left or right. This enables the cable to be run on the surface of the wall. If no spacer plate is used a recommended hole size of 7.5 mm must be drilled in the wall at the cable exit position to allow the cable to exit perpendicular to the reader.

The optional spacer plate may also be used when mounting the reader on a metal surface to reduce the negative effects of metal on the read range.

Wire Connections

The table below details the function of each wire.

Colour	Name	Function
GREY	PRESENT	Open collector output, drives low for duration of output transmission; only for Magstripe, Genscan and Basic Clock/Data formats
WHITE	CLOCK/DATA0/TTL TX	Open collector output, outputs tag ID in selected format
BROWN	DATA/DATA1	Open collector output, outputs tag ID in selected format
YELLOW	YELLOW LED	Input, controls YELLOW LED in LED Mode 1, active low
ORANGE	RED LED	Input, controls RED LED in LED Mode 1, active low
GREEN	GREEN LED	Input, controls GREEN LED in LED Mode 1 and both RED and GREEN LEDs in LED Mode 2, active low
BLUE	BEEPER	Input, controls BEEPER, active low
PURPLE	RS232 TX	Output, RS232 Tx, EIA compatible levels/polarity
RED	+VDC	Power, connect to positive of power supply (+5V to +13.6V)
BLACK	0V	Power, connect to 0V of power supply

Note 1. Open collector outputs are pulled high internally to +5V through 10k resistors.

Note 2. Inputs are pulled high internally and require to be taken low to control the beeper and LEDs, they may be left floating if unused.

Note 3. For maximum read range the supply voltage should be greater than +5.5V. For voltages in the range +5.0V to +5.5V the DC supply needs to be externally regulated.

Output Mode Selection

The 6 way switch is used to select the output format and LED mode.

SW1	SW2	SW3	SW4	Output format
ON	ON	ON	ON	Inhibit – RF field off
ON	ON	ON	OFF	RS232 – 24 bit
ON	ON	OFF	ON	RS232 – 32 bit
ON	ON	OFF	OFF	RS232 – 56 bit
ON	OFF	ON	ON	Unused
ON	OFF	OFF	OFF	Gen Scan Clock/Data – 32 bit
OFF	ON	ON	ON	Fast Mag Stripe – 40 bit
OFF	ON	ON	OFF	Mag Stripe – 24 bit
OFF	ON	OFF	ON	Mag Stripe – 32 bit
OFF	ON	OFF	OFF	Mag Stripe – 40 bit
OFF	OFF	ON	ON	Basic Clock/Data – 56 bit
OFF	OFF	ON	OFF	Wiegand 26 bit – even/odd parity
OFF	OFF	OFF	ON	Wiegand 34 bit – even/odd parity
ON	OFF	ON	OFF	Wiegand 34 bit – odd/odd parity
OFF	OFF	OFF	OFF	Wiegand 44 bit
ON	OFF	OFF	ON	Wiegand 66 bit – odd/even parity

LED Mode Selection

LED Mode	SW5	Function
1	ON	3 Individual LEDs each controlled by their own input
2	OFF	RED/GREEN with single control line (GREEN LED)

Note. In LED Mode 2, both RED and GREEN LEDs are controlled by the GREEN LED input: when the GREEN LED input is floating or pulled high, the RED LED is on and the GREEN LED is off; when the GREEN LED input is pulled low (connected to 0V), the GREEN LED is on and the RED LED is off. The YELLOW LED is always off.

Continuous/Single Transmission Mode Selection

Mode	SW6	Function
Continuous	ON	While a tag is in the field the reader continuously transmits the tag ID in the format selected by the DIP switches 1-4. Repetition rate is format dependant but varies between 80ms to 260ms
Single	OFF	When a tag enters the field the tag ID is transmitted once only. The tag must be removed from the field for at least 1 second before the same tag can be re-read and it's tag ID re-transmitted.

RS232 Output modes

There are two RS232 outputs from the reader. The purple RS232 wire outputs EIA compatible voltage levels: -V for binary '1' and +5V for binary '0'. This output is suitable to connect directly to a computer serial comm port or serial to USB adapter. The white TX wire outputs TTL levels: +5V for binary '1' and 0V for binary '0'. This output is suitable to connect directly to the USART of a microprocessor. RS232 format data is output on both wires when an RS232 mode is selected.

The format is 9600 baud, 8 data bits, no parity, and 1 stop bit.

The ID is output in the following structure:

STX(02h)	DATA(ASCII)	CR(0Dh)	LF(0Ah)	ETX(03h)
----------	-------------	---------	---------	----------

The data bytes vary according to the number of bits being output:

56 bit mode

DATA = 14 ASCII characters representing the hexadecimal ID number, e.g. '01E24310B2F12A' (30 31 45 32 34 33 31 30 42 32 46 31 32 41 hex)

32 bit mode

DATA = 10 ASCII characters representing the least significant 32 bits of the ID number, converted to decimal, e.g. '0280162602' (30 32 38 30 31 36 32 36 30 32 hex)

24 bit mode

DATA = 8 ASCII characters representing the least significant 24 bits of the ID number, converted to decimal, e.g. '11727146' (31 31 37 32 37 31 34 36 hex)

Clock/Data Mode

In this mode all 56 bits of the ID are clocked out with an eight bit header and an eight bit checksum

HEADER (11111110)	DATA (56 bits)	CHECKSUM
-------------------	----------------	----------

The HEADER is hex FE. The DATA consists of 56 ID bits sent MSB first. The checksum is the byte addition of the 7 bytes of DATA bits, e.g. ID 00000410B2F12Ah has the checksum 00h+00h+04h+10h+B2h+F1h+2Ah=E1h

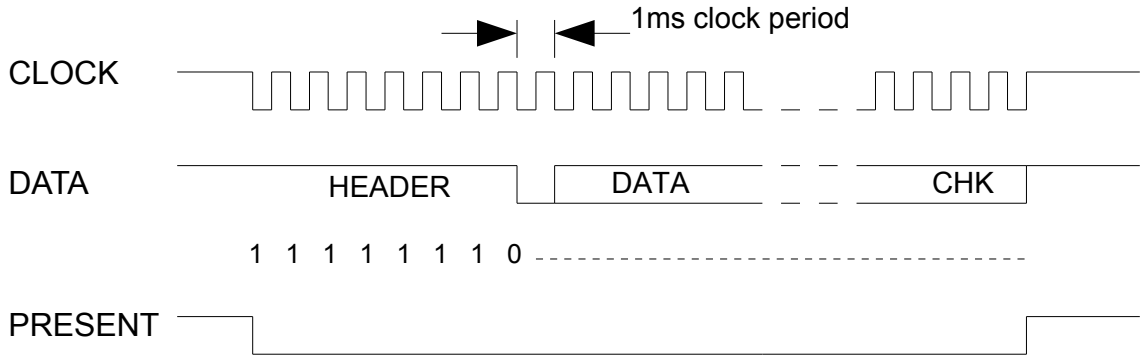

Data is set up on the falling edge of the clock and is stable on the rising edge of the clock.

Wiegand Output Modes

In this mode the ID is pulsed out on DATA0 (white wire) and DATA1 (brown wire). Both are normally high. When a tag is presented to the reader, one of 26, 34, 44 or 66 bits are transmitted in the following way:

A binary 1 is represented by a 100us pulse low on DATA1. A binary 0 is represented by a 100us pulse low on DATA0. There is a 2ms inter bit delay.

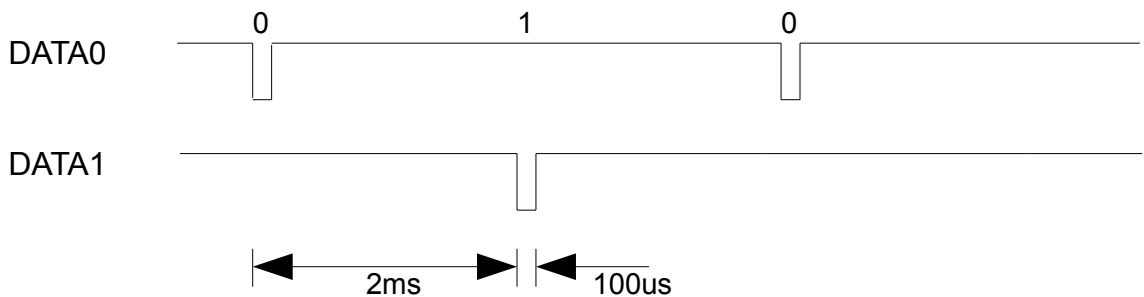

66 bit mode

66 pulses are transmitted:

- the 56 bit ID is extended to 64 bits with a leading zero
- the first bit transmitted is the odd parity of the bits 2-37
- then 64 bits of the extended ID (MSB first)
- the last bit transmitted is the even parity of the bits 30-65

44 bit mode

44 pulses are transmitted:

- the first 40 bits are the least significant 40 bits of the ID (MSB first)
- the last 4 bits are the LRC value of the previous 10 nibbles. The LRC is calculated by XORing each nibble. The MSB of the LRC is sent first

34 bit mode, odd/odd parity

34 pulses are transmitted:

- the 56 bit ID is truncated to the 32 least significant bits
- the first bit transmitted is the odd parity of the bits 2-17
- then 32 bits of the truncated ID (MSB first)
- the last bit transmitted is the odd parity of the bits 18-33

34 bit mode, even/odd parity

34 pulses are transmitted:

- the first bit is the even parity of the ID bits 9-24
- the least significant 32 bits of the ID (MSB first)
- the last bit is the odd parity of the ID bits 25-40

26 bit mode

26 pulses are transmitted:

- the first bit is the even parity of the ID bits 17-28
- the least significant 24 bits of the ID (MSB first)
- the last bit is the odd parity of the ID bits 29-40

Mag Stripe Modes

In this mode the decimal ID number is clocked out on CLOCK (white wire) and DATA (brown wire) at 100 characters per second. The format is standard as found on Track 2 of a magnetic card:

10 leading 0's	SS	DATA	ES	LRC	5 trailing 0's
----------------	----	------	----	-----	----------------

SS = start sentinel (B hex)

ES = end sentinel (F hex)

LRC = longitudinal redundancy check

DATA varies according to the number of bits selected

40 bit mode

DATA = 13 decimal digits with leading zeros. The most significant decimal digit is transmitted first.

32 bit mode

DATA = 10 decimal digits with leading zeros. The most significant decimal digit is transmitted first.

24 bit mode

DATA = 8 decimal digits with leading zeros. The most significant decimal digit is transmitted first.

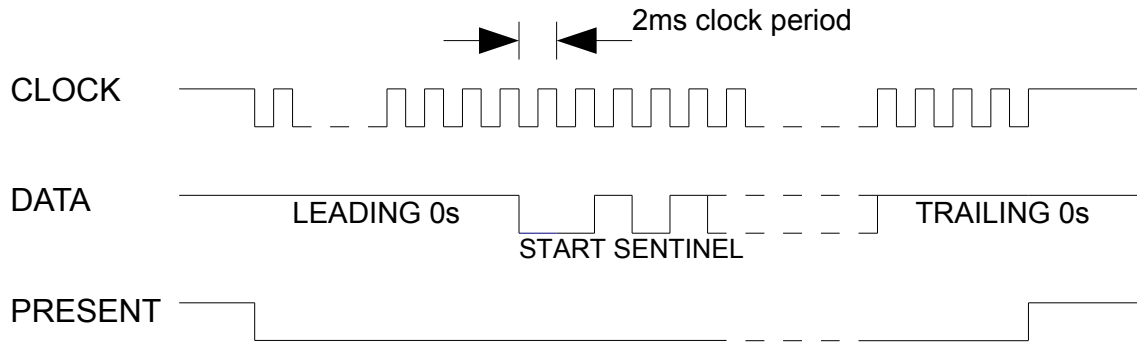

Each character is 5 bits long. The first four bits are the hex digit (0-F) least significant bit first. The fifth bit is the odd parity bit. A 0 is represented by a high level on the DATA wire and a 1 is represented by a low level on the DATA wire. Data is set up on the falling edge of the clock and is stable on the rising edge of the clock. The PRESENT output goes low for the duration of the transmission simulating the CARD PRESENT from a mag. card reader.

Fast 40 bit mode

This mode differs from the standard 40 bit magstripe mode in the following ways:

- DATA = 14 decimal digits with leading zeros
- the clock period is 200us
- ends with 10 trailing zeros

All other aspects of this format are the same as the other magstripe formats.

Gen-Scan mode

In this mode the decimal 32 bit ID is clocked out on the CLOCK (white wire) and DATA (brown wire)

20 leading zeros	SS	DATA	CHK	SEP	ES	LRC
------------------	----	------	-----	-----	----	-----

SS = start sentinel (B hex)

SEP = separator (D hex)

ES = end sentinel (F hex)

LRC = longitudinal redundancy check

DATA consists of 18 decimal digits with leading zeros. The most significant decimal digit is transmitted first

CHK is a check digit derived from the DATA using the 'modulus-10' algorithm

Clock period = 1.5ms. Data is clocked on the falling edge of the clock. The data is set up 500us before the falling edge of the clock and returns to a high level on the rising edge of the clock.

Tuning the antenna

Under the front cover is a variable capacitor which may need to be adjusted to re-tune the antenna in different environments. To tune the antenna, switch SW6 on (continuous mode), now put a card in the field and adjust the variable capacitor until the reader is beeping repeatedly (beep...beep...beep...beep...). The best tuning is when the gap between beeps is shortest.